

## PlateRite FX870II Space requirements

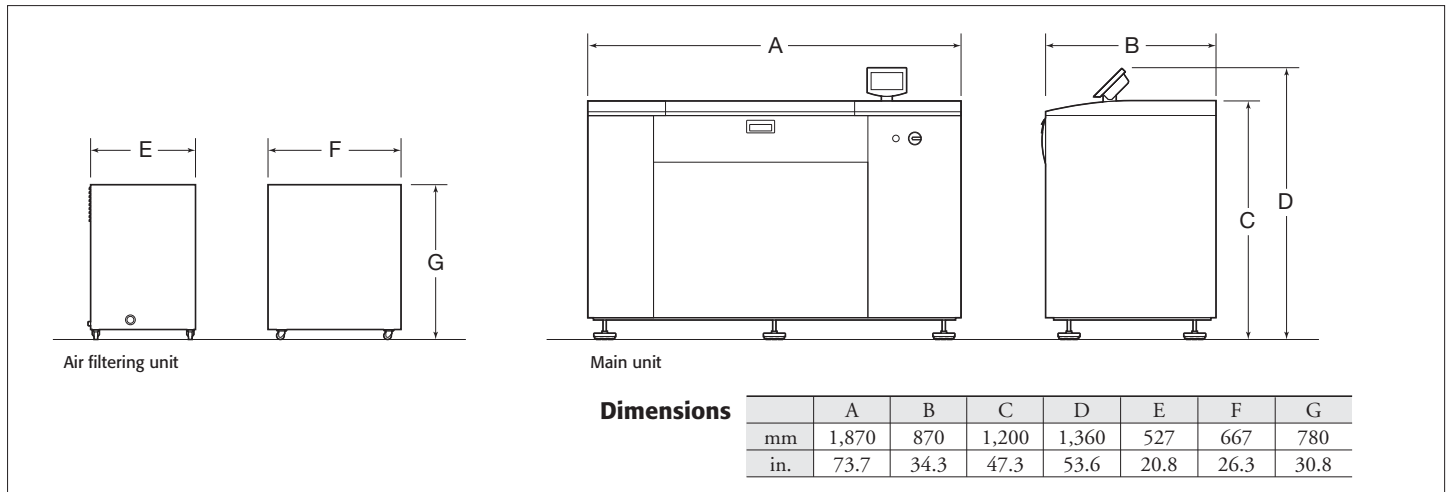

## PlateRite FX1524 and FX1200 Space requirements

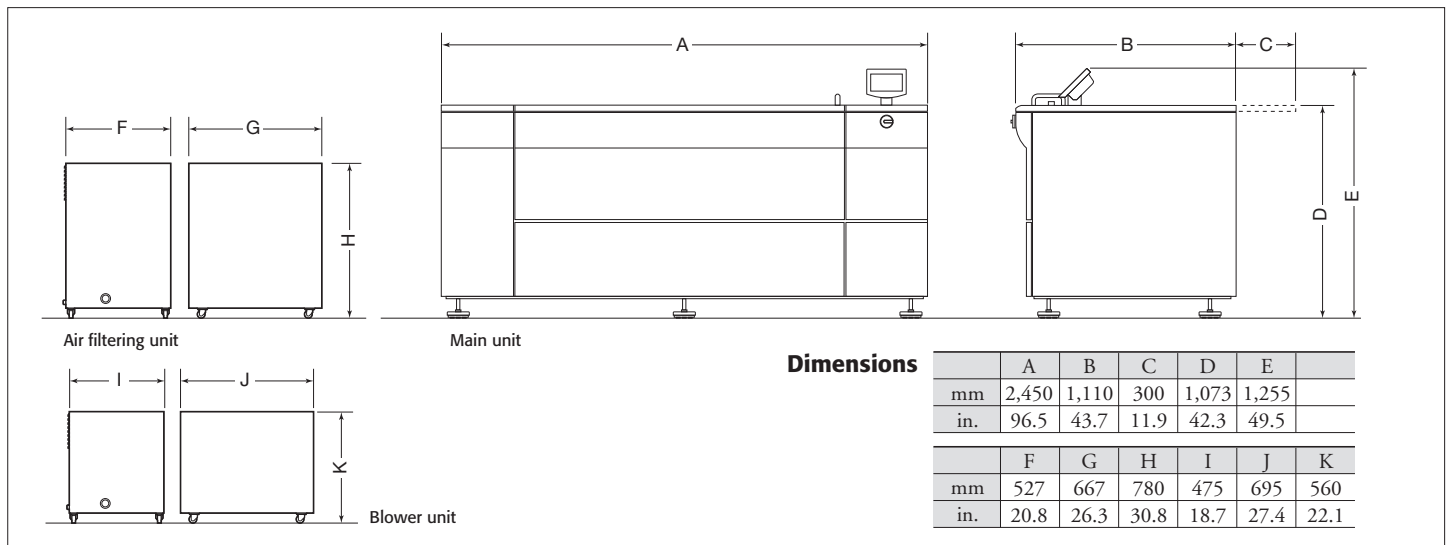

## PlateRite FX series specifications

	PlateRite FX1524	PlateRite FX1200	PlateRite FX870II
Media	Flexo digital plates, letterpress digital plates, thermal ablation film		
Media sizes	Maximum 1,067 x 1,524 mm (42.0" x 60.0"); Minimum 100 x 100 mm (4.0" x 4.0")	Maximum 1,067 x 1,200 mm (42.0" x 47.2"); Minimum 100 x 100 mm (4.0" x 4.0")	Maximum 762 x 870 mm (30.0" x 34.2"); Minimum 100 x 100 mm (4.0" x 4.0")
Media thickness	0.7 to 5.5 mm (27.6 to 216.5 mil)		
Resolution	2,400 (2,540) dpi, 4,800 dpi *1		
Productivity	4 to 6 m <sup>2</sup> /h (6,200 to 9,300 in <sup>2</sup> /h) *2		
Options	Thermal offset plate option		
Weight	Main unit: 1,120 kg (2,469 lb), air filtering unit 109 kg (239.8 lb), Blower unit: 85 kg (187 lb)		Main unit: 680 kg (1,499 lb), air filtering unit: 109 kg (239.8 lb)
Power requirements	Main unit: Single phase 200 to 240 V, 16 A, 3.2 kW Air filtering unit: Single phase 200 to 240 V, 14 A, 1.8 kW Blower unit: Single phase 200 to 240 V, 10 A, 1.2 kW		Main unit: Single phase 200 to 240 V, 16 A, 3.2 kW Air filtering unit: Single phase 200 to 240 V, 14 A, 2.2kW
Environment	Temperature: 21 to 25 °C (69.8 to 77 °F) [recommended], Relative humidity: 30 to 71% (no condensation)		

Note: Thermal ablation film support is standard with the PlateRite FX1524, FX1200 and FX870II. \*1 Supported by the standard configuration, but a 4,800 dpi screen must be purchased separately.

\*2 Productivity vary slightly depending on media sensitivity.

## DAINIPPON SCREEN MFG. CO., LTD.

### HEAD OFFICE

• Teranouchi-agaru 4-chome, Horikawa-dori, Kamigyō-ku, Kyoto, 602-8585 Japan/Phone +81-75-414-7610/Fax +81-75-414-7608

• DAINIPPON SCREEN GRAPHICS (USA), LLC

• 5110 Tollway Dr., Rolling Meadows, IL 60003, USA/Phone 917-870-7400/Fax 847-870-0149 www.screenusa.com

• DAINIPPON SCREEN (DEUTSCHLAND) GmbH

• Mundelheimer Weg 39, 40472 Düsseldorf, Germany/Phone 0211-472701/Fax 0211-4727199

• DAINIPPON SCREEN (U.K.) LTD.

• Michigan Drive, Tongwell, Milton Keynes, Buckinghamshire MK15 8HT, UK/Phone 01908-848500/Fax 01908-848501 www.screen.co.uk

• DAINIPPON SCREEN (NEDERLAND) B.V.

• Bouwerij 46, 1185 XX Amstelveen, Holland/Phone 020-4567800/Fax 020-4567805 www.screeneuropa.com

• DAINIPPON SCREEN SINGAPORE PTE. LTD.

• 29, Kaki Bukit View, Kaki Bukit Techpark II, Singapore 415963/Phone 67493833/Fax 67499010 www.screen.com.sg

• DAINIPPON SCREEN (CHINA) LTD.

• Room 2001 - 2003, 20/F Cable TV tower 9 Hoi Shing Road Tsuen Wan, N.T. Hong Kong/Phone +852-2953-0038/Fax +852-2755-8683

• Beijing office/Phone 010-6708-9271, 9272, 9273/Fax 010-6708-9395

• Shanghai office/Phone 021-3126-5122/Fax 021-5218-2199

• Guangzhou office/Phone 020-3891-1112/Fax 020-3891-1036

• DAINIPPON SCREEN (TAIWAN) CO., LTD.

• 4F No. 126-1, Ming Tsu West Rd., Taipei, Taiwan/Phone 02-25862711/Fax 02-25914367

• DAINIPPON SCREEN (KOREA) CO., LTD.

• 10th Yonsei Bongnae B/D 48-3, 1Ga, Bongnae-Dong, Joong-Gu, Seoul 100-161, Korea/Phone 02-7766-786/Fax 02-7766-787

• DAINIPPON SCREEN (AUSTRALIA) PTY. LTD.

• Suite 11, 2 Eden, Park Drive, Macquarie, NSW2133, Australia/Phone +61-2-9016-3400/Fax +61-2-9016-3425

Internet web site : [www.screen.co.jp](http://www.screen.co.jp)  
[www.screenusa.com](http://www.screenusa.com)  
[www.screeneuropa.com](http://www.screeneuropa.com)

• This brochure was made using SPEKTA 2 screening.

We reserve the right to alter product design and specifications without prior notice.

## PlateRite FX Series

Flexo/Letterpress CtP



The PlateRite FX series are high-quality, easy to use, reliable CtP recorders that offer optimal flexo/letterpress plate output for printing and prepress companies. They can image the black mask layer of resin plates directly, thereby eliminating the need for film and other intermediate processing. This results in more efficient operations, as well as more consistent output quality. What's more, the PlateRite FX series units' superior halftone dot reproduction ensures consistently high quality printing even in the highlight and shadow areas.

The PlateRite FX1524 and FX1200 are designed for a wide range of uses, including the production of labels, flexible packaging, cartons, and corrugated packaging. Plates up to 1,067 × 1,524 mm (42.0" × 60.0") for FX1524 and up to 1,067 × 1,200 mm (42.0" × 47.2") for FX1200 can be loaded onto their drum with ease, ensuring high-precision, high-quality output of resin plates.

The PlateRite FX870II is the ideal flexo/letterpress CtP recorder for printing companies that already possess letterpress printing presses but want higher quality output, as well as for companies looking to improve the quality of the labels output from their intermittent letterpress printing presses, offset label printing presses, or flexo combination printing presses.

\*In their standard configuration, the PlateRite FX1524, FX1200 and FX870II support a maximum output resolution of 4,800 dpi.

## PlateRite FX870II



*High Quality  
Easy Operation  
Superior Workflow  
High-end Screening*

**PlateRite FX1200** **NEW**

**PlateRite FX1524**



## High Quality

### Consistent plate quality

The PlateRite FX Series eliminate many of the problems associated with platemaking using film, including image unevenness, problems caused by dust, and UV scattering. They also eliminate the many problems inherent in going from film to plate, such as misalignment of the film during platemaking and registration errors arising from stretching of the film. This helps ensure consistent plate quality and reduces the waste inherent in repeating plate output due to errors.

### Proven technology

The light source used by the PlateRite FX units, a multi-channel laser diode, is the same type of laser as those used in Screen's traditional offset CTP recorders. This proven, reliable, high-powered laser images the black mask layer of resin plates. In addition to enabling sharp imaging, the PlateRite FX units' light source is both long-lived and inexpensive to operate.

### Superior reproduction of fine lines and white knockout text

With CtP plates, scattering of the UV light during plate imaging is eliminated, so sharp relief patterns can be created. This ensures superior reproduction of fine lines and white knockout text.

### High-quality plate output

Unlike traditional printing plates, CtP plates can include both highlight relief patterns and shadow cutouts, which ensures that the minimum and maximum halftone dot sizes are reproduced accurately. This dramatically increases quality from the highlights to the shadows, across a wide range of image densities.

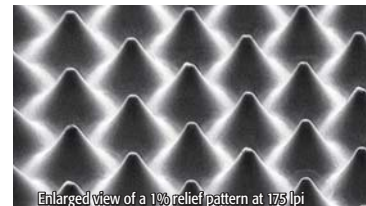

### 4,800 dpi resolution for high-quality output

The PlateRite FX Series offer a maximum output resolution of 4,800 dpi. This high resolution significantly reduces the incidence of problems common in low-resolution output, such as jaggies in diagonal lines and curves, and dramatically improves the repeatability of fine line reproduction. 4,800 dpi output also delivers smooth gradations, and almost completely eliminates unevenness, even in the highlight areas.

Enlargement of the 1-point characters



4,800 dpi

2,400 dpi

## Easy Operation

### PlateRite FX870II

Loading plates onto the drum is simple. The operator simply uses clamps to fix the leading edge of the resin plate in place and then attaches the trailing edge with tape. Leading edge clamps, paired with the design of the suction gutters on the face of the drum, make it possible for the PlateRite FX870II to handle a variety of plates ranging from a minimum of 100 x 100 mm (4.0" x 4.0") to a maximum of 762 x 870 mm (30.0" x 34.2"). This makes the PlateRite FX870II perfect for producing the A3 and A4 size plates that are standard in the label industry, while also providing the flexibility to produce larger, A1 size plates.

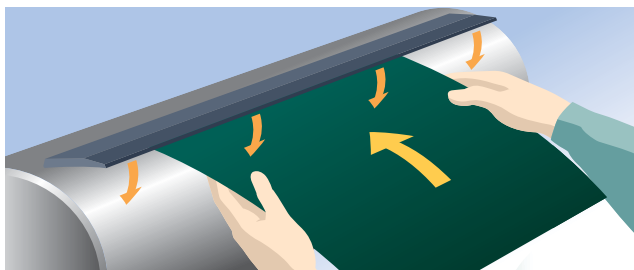

### PlateRite FX1524 / PlateRite FX1200

Leading and trailing edge clamps save the operator time and trouble when H1,067 mm (42.0") plates are used. The PlateRite FX1524 and FX1200 features a button operated loading mechanism, which loads plates reliably. Manual plate loading is also available, and the operator can choose the optimal plate loading procedure depending on the size of plate being used.

Note: The minimum supported plate size is 100 x 100 mm (4.0" x 4.0").



## Superior Workflow

### Advanced, fully digital processing for higher efficiency

The combination of Trueflow SE Rite Flexo and FlatWorker Flexo Edition promotes increased efficiency throughout the production workflow, as does the combination of third-party workflows and PageFit Flexo. Operators can create layout instructions and check resin plate layout on a monitor, and there is no need for manual operations such as page imposition or adjusting the position of different elements. The use of Trueflow SE Rite Flexo and FlatWorker Flexo Edition or PageFit Flexo makes efficient, reliable creation of resin plates a reality.

### Trueflow SE Rite Flexo

Trueflow SE Rite Flexo is an entry-level workflow RIP that features Adobe Systems' latest RIP engine, Adobe® PDF Print Engine®, and boasts all the essential functions required for flexo/letterpress CtP output. It can be upgraded to Trueflow SE after purchase, which makes it the perfect tool for companies that anticipate future growth.

### FlatWorker Flexo Edition/PageFit Flexo

FlatWorker Flexo Edition and PageFit Flexo efficiently position screened 1-bit TIFF data on resin plates. Layout can be carried out automatically, or by dragging and dropping the desired data. It's easy to make fine adjustments to the position of the data after initial positioning. The operator can also check the positioning on screen in real time, which reduces waste during platemaking by preventing the output of incorrect plates. PageFit Flexo emphasizes Screen's ability to communicate with a third-party workflow. Utilizing pre-screened 1-bit TIFF data from other front end systems. PageFit Flexo will automatically impose 1-bit TIFF data to maximize plate usage. FlatWorker Flexo is a must see Screen product that integrates directly with Trueflow SE Rite Flexo.

### LabProof SE

LabProof SE is a high quality, high cost performance color proofing system that outputs proofs on inkjet printers, while making the most of the advantages of inkjet printing. It accepts RIP'ed files such as CMYK TIFF and 1-bit TIFF files and outputs them on large-size inkjet printers. LabProof SE measures color charts and carries out color matching based on industry-standard ICC profiles, so the color proofs it outputs are remarkably similar to the final printed product.

#### FlatWorker Workflow

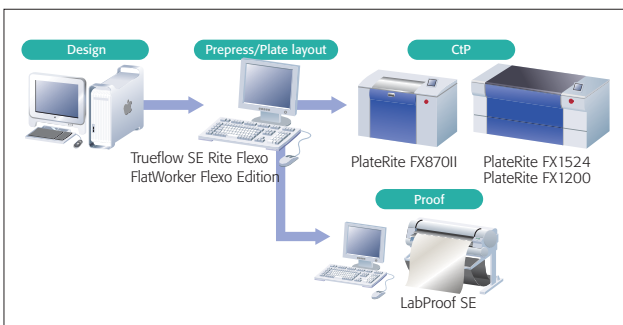

#### PageFit Flexo Workflow

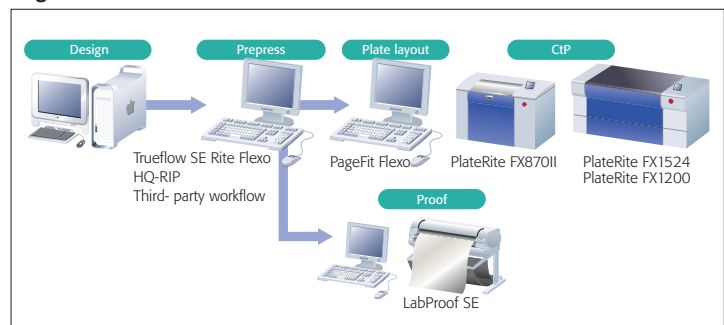

Output data is split into separations, and multiple jobs can be output on a single plate.

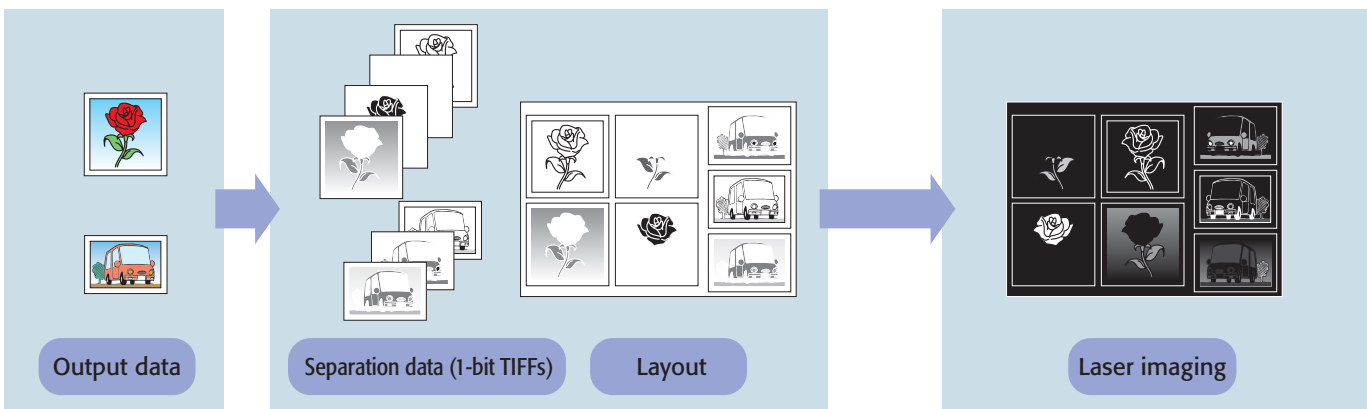

# High-end Screening

## AM screening

### For flexo and letterpress printing

AM screening, which is the form of screening used most commonly in the printing industry today, involves creating halftone dots separated by a fixed distance and arranged in a regular pattern. Varying the size of the halftone dots used creates areas of higher and lower color density. AM screening results in a highly consistent color appearance, and is easy to print.

## Flexo Dot

### Flexo printing

Flexo Dot, which is designed for flexo printing, increases the minimum dot size and applies a reinforcing pattern to the base halftone dot shape. This results in the creation of more consistent relief patterns in the highlight areas. The minimum halftone dot shape can be selected from a lineup of shapes for each screen ruling, depending on the plate thickness, platemaking and printing environments, to ensure optimal highlight printing.

### Letterpress printing

With traditional AM halftone dots, the reproduction of extreme highlights is inconsistent. In traditional halftone dots, the minimum halftone dot size is one dot, but with Flexo Dot, highlight areas feature a somewhat larger minimum halftone dot size consisting of several dots, which makes it possible to create consistent dots in the extreme highlight areas. The minimum halftone dot shape can be selected from a lineup of shapes for each screen ruling, depending on the platemaking and printing environments, to ensure optimal highlight printing.

## Spekta 2

### Offset and letterpress printing

Spekta 2 is a next-generation form of hybrid AM/FM screening that is designed to make printing easier. Not only does it solve the problems of moiré and broken lines that sometimes occur when AM screening is used, it also increases the vibrancy of the colors being printed. Spekta 2 makes added-value label printing a reality.

## Multi-screening (option)

Multi-screening makes it possible to use the optimal type of screening for each object being printed, even if that means mixing different types of screening on a single page. This is particularly useful when printing pages that contain such disparate elements as images, text, keylines, patterned backgrounds, tints, decorative lines, outlined text, and gradations. Multi-screening prevents moiré and broken lines, and contributes to a significant increase in finished quality.

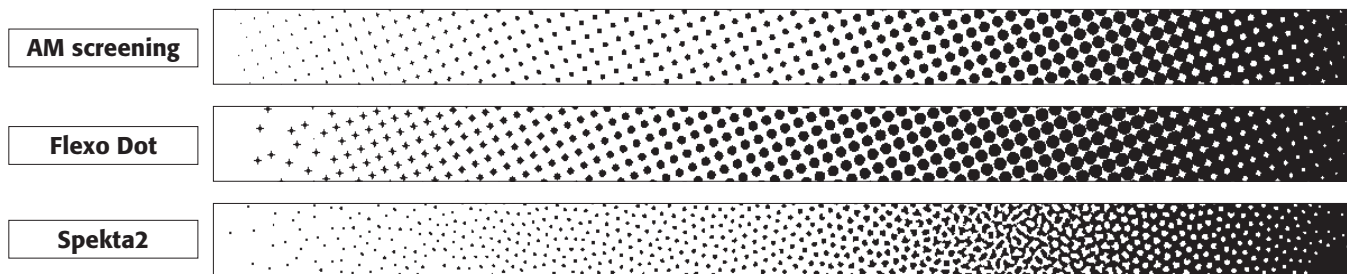
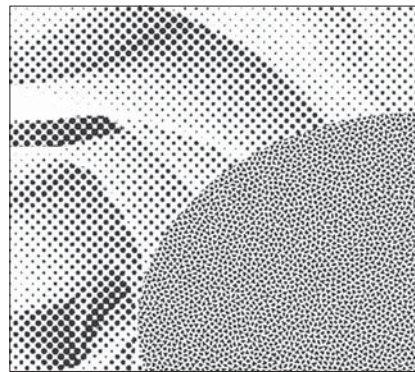

## Flexo Dot 4800dpi /210lpi

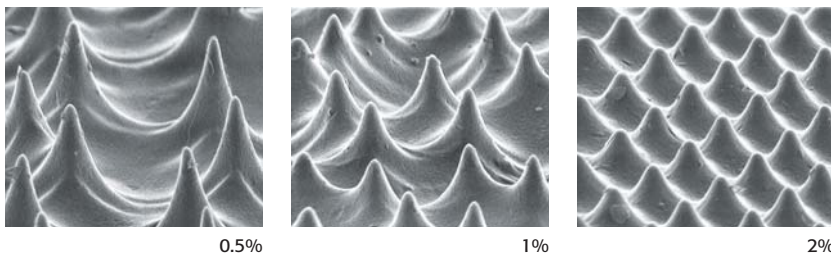

The PlateRite FX series can handle a wide variety of plates, including flexo plates, letterpress plates, and more.

### Thermal offset plate option

The PlateRite FX870II offers output of thermal offset plates as an option. Thermal offset plates are suitable for high quality sticker and label printing.