

PlateRite 4300
Thermal Plate Recorder

CTP



Innovation & Reliability

High-quality thermal CTP for 4-page presses

Dainippon Screen's thermal Computer-to-Plate (CTP) solutions are unbeatable for their quality, accuracy, and reliability. They consistently output plates with a dot sharpness and registration accuracy that enable superior process control and fast makeready times. They also offer the benefits of easy daylight handling and exceptional production efficiency for both short and long runs.

Screen's PlateRite 4300S and PlateRite 4300E are specially designed to provide optimal versatility in plate production for 4-page and 2-page presses. The PlateRite 4300S is a high-speed model that can comfortably and consistently output up to 21 plates per hour when working with 724 x 615 mm (28.5" x 24.2") plates at 2400 dpi. The PlateRite 4300E is an affordable entry-level solution that offers the same high-quality features as the PlateRite 4300S, and provides output at up to 11 plates per hour. Both models have a proven external-drum design and come with the option of inline punching blocks to help ensure perfect on-press register and faster makeready times.

The choice has never been easier for making the move to high-quality thermal CTP.



Versatile and easy to use

Output suitable for 2-page or 4-page presses

Support for a wide range of plate sizes

The PlateRite 4300S and PlateRite 4300E can handle the plate requirements of new larger-format 4-page presses. Both support a maximum plate size of 830 x 660 mm (32.6" x 25.9"), and are also capable of supporting some of the smaller 2-page presses with a minimum plate size of 324 x 370 mm (12.8" x 14.6")*. The PlateRite 4300S and PlateRite 4300E offer an unbeatably flexible and reliable solution for fast output of a wide variety of plate sizes.

* 304 x 370 mm (12" x 14.6") support is available as a factory option.

Auto-balance for different plate sizes

Auto-balance lets you use different sized plates without making any manual adjustments for correct drum balance. All you do is select the type of plate you want to use and the PlateRite 4300S and PlateRite 4300E automatically make the necessary adjustments to create perfect drum balance for each plate size. The PlateRite 4300S and PlateRite 4300E also feature separate loading and unloading bays, so that one plate can be readied for loading while another is being exposed.

Bring out the ideal CTP environment with a simple upgrade

For the ideal environment for your increased productivity needs, you can upgrade your PlateRite 4300E to the PlateRite 4300S* by simply exchanging parts required for the PlateRite 4300E. This reduces wasted expenses and improves the operational efficiency of your platesetter.

* Please see the specifications sheet for information on the resolutions available when upgrading to the PlateRite 4300S.

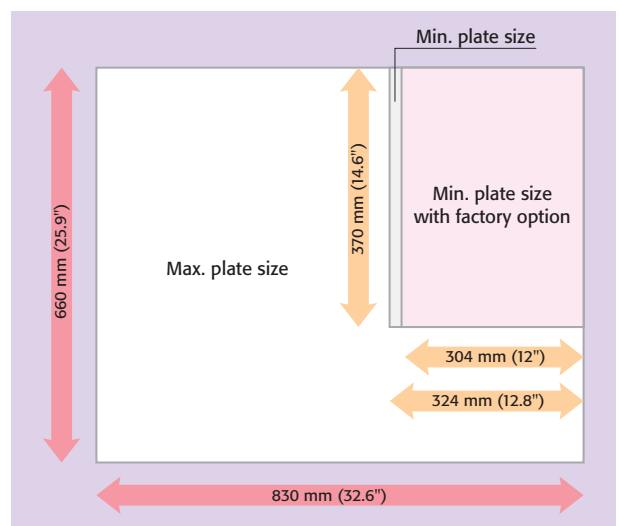

Productivity-enhancing automation

Optional inline punching and automated plate loading

Automatic inline punch

Screen's automatic inline punching system is the industry leader for enabling perfect register on press. It does this by performing two types of punching (for press and platesetter registration) at the same time, immediately before mounting the plate on the drum. This method gives much greater registration accuracy compared with either manual or off-line punching, eliminates human error and achieves faster press makeready. Punch blocks from Heidelberg, Komori, Bacher, Protocol, Stoesser, Grapho Metronic and Screen are available, covering the full range of sizes for all major press types. Up to four punch blocks can be mounted and selected according to plate size and press type.

Autoloader options

The PlateRite 4300S and PlateRite 4300E can be configured for efficient automatic operation with Screen's optional autoloaders, which are acclaimed in the market for their reliability and precision. Both the PlateRite 4300S and PlateRite 4300E can be paired with the SA-L4300II single-cassette autoloader. This high-quality unit can hold up to 100 plates and automatically removes interleaf paper before loading each plate. It is also possible to upgrade from the SA-L 4300II to the MA-L 4300II multi-cassette autoloader, which comes standard with three cassettes and enables up to 300 plates of three different sizes to be loaded and imaged in the PlateRite 4300S without operator intervention. The PlateRite 4300S and PlateRite 4300E can also be paired with the more economical SA-L 4100* single-cassette autoloader.

Both the PlateRite 4300S and PlateRite 4300E are supported by an automatic processor bridge, which extends process automation all the way through to the plate processor.

* The SA-L 4100 has a capacity of 50 plates and requires manual interleaf removal.

SA-L4100 single-cassette autoloader specifications

| | |
|------------------------|---|
| Plate transport | Automatic, but requires manual removal of interleaf paper |
| Cassette capacity | 50 plates (same size only) |
| Dimensions (W x D x H) | 1,260 x 1,335 x 1,031 mm (49.7" x 52.6" x 40.6") |
| Weight | Approx. 200 kg (441 lb) |
| Power | Powered by main unit |
| Environment | Same as main unit |
| Standard accessories | Plate cassette with cassette carrier |

SA-L 4300II single-cassette autoloader specifications

| | |
|------------------------|--|
| Plate transport | Fully automatic loading & automatic interleaf removal |
| Cassette capacity | 100 plates |
| Dimensions (W x D x H) | 1,395 x 1,735 x 1,027 mm (55" x 68.4" x 40.5") |
| Weight | Approx. 340 kg (748 lb) |
| Power | Powered by main unit |
| Environment | Same as main unit |
| Standard accessories | Plate cassette and carrier, interleaf paper collection box |
| Options | Additional plate cassettes and carriers (with cassette covers) |

MA-L 4300II multi-cassette autoloader specifications

| | |
|------------------------|---|
| Plate transport | Fully automatic loading & automatic interleaf removal |
| Cassette capacity | 300 plates |
| No. of cassettes | 3 cassettes |
| Cassette transport | Fully automatic (horizontal/vertical) |
| Dimensions (W x D x H) | 2,590 x 1,735 x 1,027 mm (102" x 68.4" x 40.5") |
| Weight | Approx. 765 kg (1,683 lb) |
| Power | Powered by main unit |
| Environment | Same as main unit |
| Standard accessories | 3 cassettes, interleaf paper collection box |



PlateRite 4300 with MA-L 4300II

Space requirements

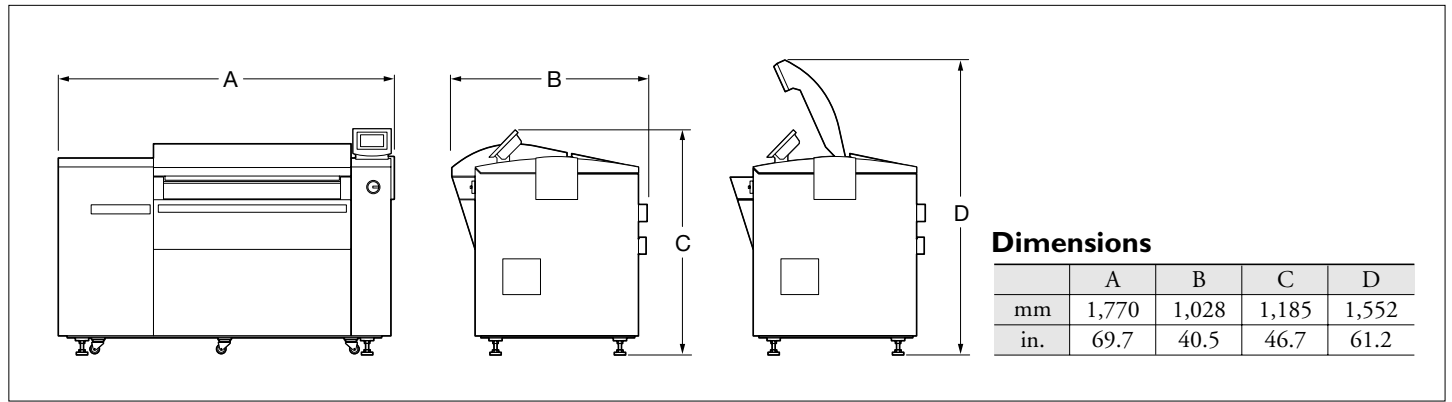

PlateRite 4300S/4300E specifications

| Product name | PlateRite 4300S | PlateRite 4300E |
|--------------------------|---|--|
| Recording system | External drum | |
| Light source | 32-channel infrared laser diodes | 16-channel infrared laser diodes |
| Plate sizes | Maximum 830 x 660 mm (32.6" x 25.9"); Minimum 324 x 370 mm (12.8" x 14.6") (Compatible with 304 x 370 mm [12" x 14.6"] plate sizes as a factory option) | |
| Exposure size | Maximum 830 x 633 mm (32.6" x 24.9") [15-mm (0.5") leading edge clamp and 12-mm (0.4") trailing edge clamp] | |
| Media | Thermal (infrared sensitive) plates | |
| Media thickness | 0.15 to 0.3 mm (5.9 to 11.8 mil) | |
| Resolutions | 1,200/2,000/2,400/2,438/2,540/4,000 dpi | 2,400/2,438/2,540 dpi (1,200 dpi resolution when upgrading to the PT-R4300S from the PT-R4300E) |
| Repeatability | ±5 microns* ¹ | |
| Productivity | 21 plates/hr at 2,400 dpi (724 x 615 mm/28.5" x 24.2")* ² | 11 plates/hr at 2,400 dpi (724 x 615 mm/28.5" x 24.2")* ² |
| Interface | Fast PIF | |
| Plate transport | Semiautomatic loading (standard) Fully automatic loading (optional) Processor bridge (optional) | |
| Punch systems (optional) | SCREEN, Heidelberg, Protocol, Komori, and others | |
| Dimensions (W x D x H) | Main unit: 1,770 x 1,028 x 1,185 mm (69.7" x 40.5" x 46.7") Blower unit: 429 x 600 x 361 mm (16.9" x 23.7" x 14.3") | |
| Weight | Main unit: 670 kg (1,474 lb) Blower unit: 25 kg (55 lb) | |
| Environment | Recommended: 21 to 25°C (69.8 to 77°F) Required: 18 to 26°C (64.4 to 78.8°F) Relative humidity: 40 to 70% (no condensation) | |
| Power requirements | Single phase 200 to 240 V, 20 A, 4.0 kW SA-L, MA-L, AT-T, and blower unit are powered by main unit. | |
| Standard accessories | Blower unit | |
| Options | Single-cassette autoloaders SA-L 4100/SA-L 4300II, multi-cassette autoloader MA-L 4300II, processor bridge AT-T 4000, punch system. Support for 12 mm front margin and small size 304 mm plates as factory options. | |

*¹ Over four consecutive exposures on one plate at 23°C (73.4°F) and 60% relative humidity.

*² Productivity may vary depending upon media sensitivity.

DAINIPPON SCREEN MFG. CO., LTD.

HEAD OFFICE

• Teranouchi-agaru 4-chome, Horikawa-dori, Kamigyo-ku, Kyoto, 602-8585 Japan/Phone +81-75-414-7610/Fax +81-75-414-7608

SCREEN (USA)

• 5110 Tolliver Dr., Rolling Meadows, IL 60008, USA/Phone 847-870-7400/Fax 847-870-0149 www.screenusa.com

DAINIPPON SCREEN (DEUTSCHLAND) GmbH

• Mündelheimer Weg 39, 40472 Düsseldorf, Germany/Phone 0211-472701/Fax 0211-4727199/Telex 858-4438 DSDD D

DAINIPPON SCREEN (U.K.) LTD.

• Michigan Drive, Tongwell, Milton Keynes, Buckinghamshire MK15 8HT, UK/Phone 01908-848500/Fax 01908-848501 www.screen.co.uk

DAINIPPON SCREEN (NEDERLAND) BV

• Bouwerij 46, 1185 XX Amstelveen, Holland/Phone 020-4567805 Fax 020-4567805 www.screeneurope.com

SCREEN FRANCE

• Z.I. Paris Nord II, 12 Rue des Chardonnerets, B.P. 50315, F-95940 ROISSY C.D.G. Cedex, France/Phone 1-48-17-86-00/Fax 1-48-17-86-01

DAINIPPON SCREEN SINGAPORE PTE. LTD.

• 29, Kaki Bukit View, Kaki Bukit Technopark II, Singapore 415963/Phone 67493833/Fax 67499010 www.screensp.com.sg

DAINIPPON SCREEN (CHINA) LTD.

• 8th Floor, 414 Kwun Tong Road, Kwun Tong, Kowloon, Hong Kong/Phone 2953-0038/Fax 2755-8683

Beijing office /Phone 010-6708-9271, 9272, 9273/Fax 010-6505-4975 (China)

Shanghai office /Phone 021-6466-4501/Fax 021-6466-4503 (China)

Guangzhou office/Phone 020-3891-1112/Fax 020-3891-1036 (China)

DAINIPPON SCREEN (TAIWAN) CO., LTD.

• 4F No. 125-1, Ming Tsu West Rd., Taipei, Taiwan/Phone 02-25862711/Fax 02-25914367

DAINIPPON SCREEN (KOREA) CO., LTD.

• 8th Yonsai Bongnae B/D 48-3, 1Ga, Bongnae-Dong, Joong-Gu, Seoul 100-161, Korea/Phone 02-7766-786/Fax 02-7766-787

DAINIPPON SCREEN (AUSTRALIA) PTY. LTD.

• Unit 2, 207-209 Young Street, Waterloo, NSW 2017, Australia/Phone 02-9310-1314/Fax 02-9310-3566

Internet web site : www.screen.co.jp

www.screenusa.com

www.screeneurope.com

- This brochure was made using Spekta 2 screening.
- Printed on recycled paper.

We reserve the right to alter product design and specifications without prior notice.

SCREEN

ADVANCING THE FUTURE OF PRINT

PlateRite 4300

Thermal Plate Recorder

CTP



Space requirements

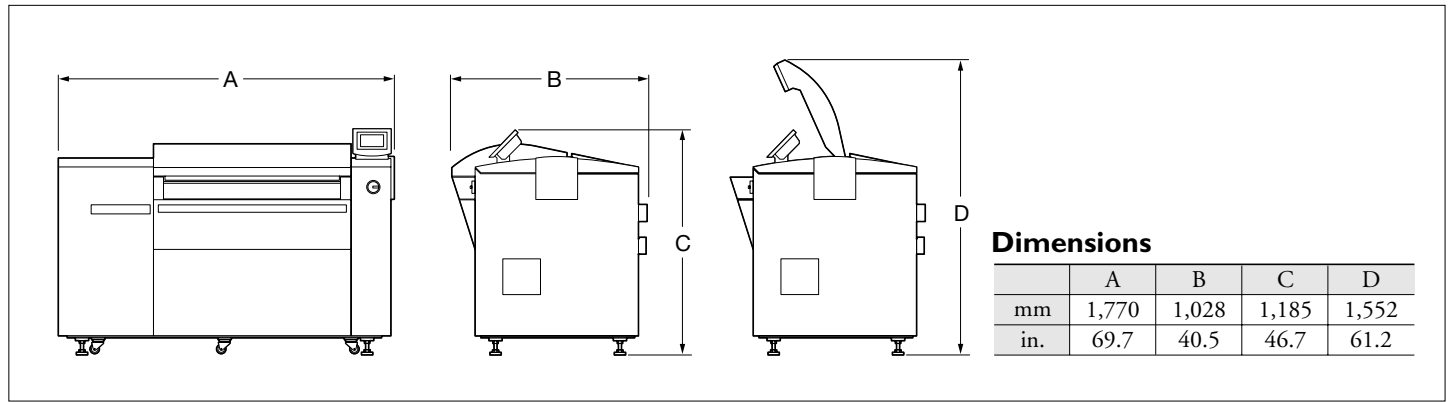

PlateRite 4300S/4300E specifications

| Product name | PlateRite 4300S | PlateRite 4300E |
|--------------------------|---|--|
| Recording system | External drum | |
| Light source | 32-channel infrared laser diodes | 16-channel infrared laser diodes |
| Plate sizes | Maximum 830 x 660 mm (32.6" x 25.9"); Minimum 324 x 370 mm (12.8" x 14.6") (Compatible with 304 x 370 mm [12" x 14.6"] plate sizes as a factory option) | |
| Exposure size | Maximum 830 x 633 mm (32.6" x 24.9") [15-mm (0.5") leading edge clamp and 12-mm (0.4") trailing edge clamp] | |
| Media | Thermal (infrared sensitive) plates | |
| Media thickness | 0.15 to 0.3 mm (5.9 to 11.8 mil) | |
| Resolutions | 1,200/2,000/2,400/2,438/2,540/4,000 dpi | 2,400/2,438/2,540 dpi (1,200 dpi resolution when upgrading to the PT-R4300S from the PT-R4300E) |
| Repeatability | ±5 microns*1 | |
| Productivity | 21 plates/hr at 2,400 dpi (724 x 615 mm/28.5" x 24.2")*2 | 11 plates/hr at 2,400 dpi (724 x 615 mm/28.5" x 24.2")*2 |
| Interface | Fast PIF | |
| Plate transport | Semiautomatic loading (standard) Fully automatic loading (optional) Processor bridge (optional) | |
| Punch systems (optional) | SCREEN, Heidelberg, Protocol, Komori, and others | |
| Dimensions (W x D x H) | Main unit: 1,770 x 1,028 x 1,185 mm (69.7" x 40.5" x 46.7") Blower unit: 429 x 600 x 361 mm (16.9" x 23.7" x 14.3") | |
| Weight | Main unit: 670 kg (1,474 lb) Blower unit: 25 kg (55 lb) | |
| Environment | Recommended: 21 to 25°C (69.8 to 77°F) Required: 18 to 26°C (64.4 to 78.8°F) Relative humidity: 40 to 70% (no condensation) | |
| Power requirements | Single phase 200 to 240 V, 20 A, 4.0 kW SA-L, MA-L, AT-T, and blower unit are powered by main unit. | |
| Standard accessories | Blower unit | |
| Options | Single-cassette autoloaders SA-L 4100/SA-L 4300II, multi-cassette autoloader MA-L 4300II, processor bridge AT-T 4000, punch system. Support for 12 mm front margin and small size 304 mm plates as factory options. | |

*1 Over four consecutive exposures on one plate at 23°C (73.4°F) and 60% relative humidity.

*2 Productivity may vary depending upon media sensitivity.

DAINIPPON SCREEN MFG. CO., LTD.

HEAD OFFICE

• Teranouchi-agaru 4-chome, Horikawa-dori, Kamigyo-ku, Kyoto, 602-8585 Japan/Phone +81-75-414-7610/Fax +81-75-414-7608

SCREEN (USA)

• 5110 Tollview Dr., Rolling Meadows, IL 60008, USA/Phone 847-870-7400/Fax 847-870-0149 www.screenusa.com

DAINIPPON SCREEN (DEUTSCHLAND) GmbH

• Mündelheimer Weg 39, 40472 Düsseldorf, Germany/Phone 0211-472701/Fax 0211-4727199/Telex 858-4438 DSDD D

DAINIPPON SCREEN (U.K.) LTD.

• Michigan Drive, Tongwell, Milton Keynes, Buckinghamshire MK15 8HT, UK/Phone 01908-848500/Fax 01908-848501 www.screen.co.uk

DAINIPPON SCREEN (NEDERLAND) BV

• Bouwerij 46, 1185 XX Amstelveen, Holland/Phone 020-4567800/Fax 020-4567805 www.screen-europe.com

SCREEN FRANCE

• Z.I. Paris Nord II, 12 Rue des Chardonnerets, B.P. 50315, F-95940 ROISSY C.D.G. Cedex, France/Phone 1-48-17-86-00/Fax 1-48-17-86-01

DAINIPPON SCREEN SINGAPORE PTE. LTD.

• 29, Kaki Bukit View, Kaki Bukit Technopark II, Singapore 415963/Phone 67493833/Fax 67499010 www.screensp.com.sg

DAINIPPON SCREEN (CHINA) LTD.

• 8th Floor, 414 Kwun Tong Road, Kwun Tong, Kowloon, Hong Kong/Phone 2953-0038/Fax 2755-8683

Beijing office /Phone 010-6708-9271, 9272, 9273/Fax 010-6505-4975 (China)

Shanghai office /Phone 021-6466-4501/Fax 021-6466-4503 (China)

Guangzhou office/Phone 020-3891-1112/Fax 020-3891-1036 (China)

DAINIPPON SCREEN (TAIWAN) CO., LTD.

• 4F No. 125-1, Ming Tsu West Rd., Taipei, Taiwan/Phone 02-25862711/Fax 02-25914367

DAINIPPON SCREEN (KOREA) CO., LTD.

• 8th Yonsai Bongnae B/D 48-3, 1Ga, Bongnae-Dong, Joong-Gu, Seoul 100-161, Korea/Phone 02-7766-786/Fax 02-7766-787

DAINIPPON SCREEN (AUSTRALIA) PTY. LTD.

• Unit 2, 207-209 Young Street, Waterloo, NSW 2017, Australia/Phone 02-9310-1314/Fax 02-9310-3566

Internet web site : www.screen.co.jp

www.screenusa.com

www.screen-europe.com

- This brochure was made using Spekta 2 screening.
- Printed on recycled paper.

We reserve the right to alter product design and specifications without prior notice.